

*fatra*

Tiles  
**FATRASTEP**



## DESCRIPTION

Multifunctional injection moulded plastic tiles with locking system designed for seasonal outdoor use.

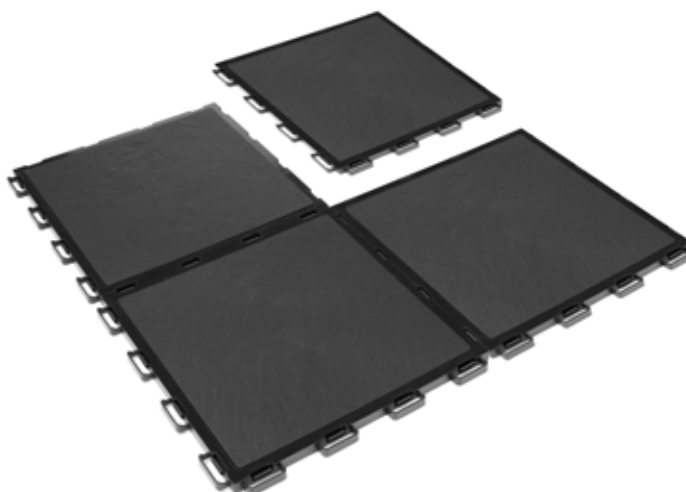

## TECHNICAL INFORMATION

- Material polypropylene
- Tile dimension 300 x 300 mm
- Tile thickness 13 mm
- Weight 3.50 kg/m<sup>2</sup>
- Crush strength 5 MPa
- Resistance to temperature -30 °C to 70 °C
- Package 9 tiles = 0.81 m<sup>2</sup> = 2835 g  
pallet (127 x 96 x 126 cm), 108 sets = 310 kg



## APPLICATIONS

- Decorative tiles for terraces and patios, balconies, pergolas and gazebos.
- Paving around swimming pools and hot tubs.
- Outdoor use in gardens, campsites and other outdoor areas.

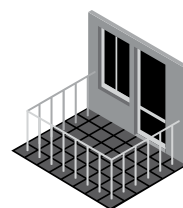
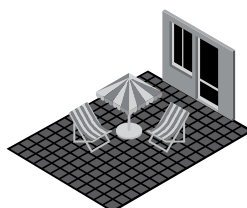
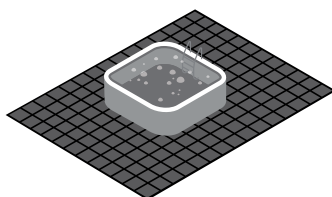
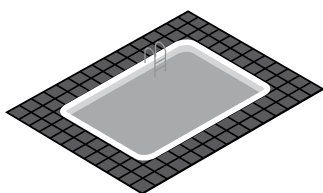

**FATRASET**

## ADVANTAGES

---

- Easy assembly thanks to the locking system, simple handling. It is assembled without using tools..
- Easy maintenance.
- Resistant to UV, thermal stress.
- Surface with great water draining capabilities.
- Protects surfaces from damage, scratches, moisture, etc.
- Made of polypropylene = resistant to oils and solvents, cold and weather conditions.

## LAYING INSTRUCTIONS

---

- The tiles shall be laid loosely on a flat substrate using a locking system – the individual tiles are simply mechanically connected using locks and counter-locks.

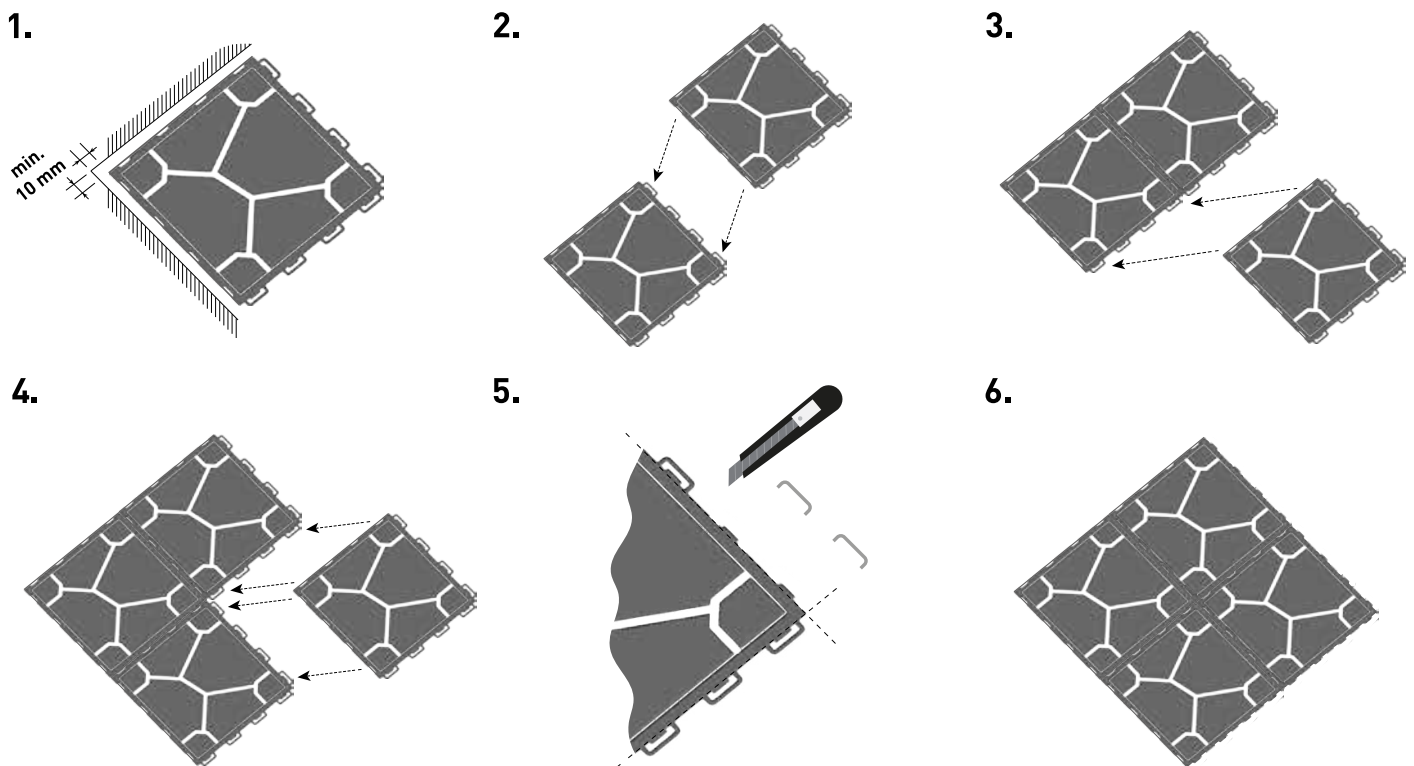

## MAINTENANCE

---

- Ordinary cleaning methods can be used – mechanical cleaning; water and detergent.

# FINISH

FATRASTEP Slateris  
slate

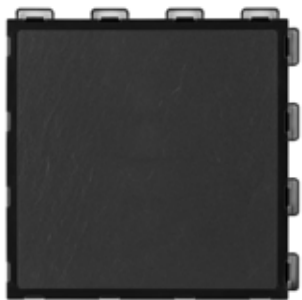

FATRASTEP Stoneris  
grey



FATRASTEP Stoneris  
black

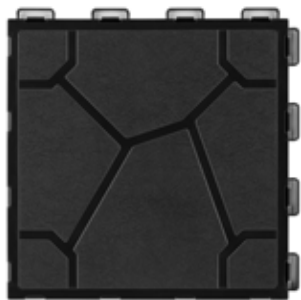

FATRASTEP Lineris  
brown



# DETAIL

Lock



Underside

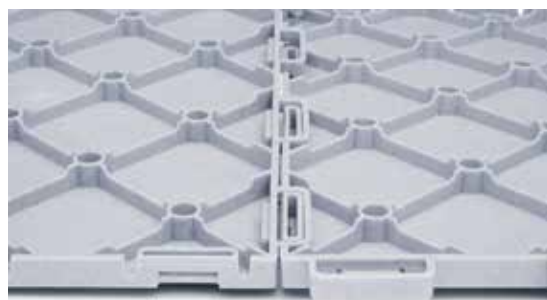

**30 x 30 cm, 9-pack**

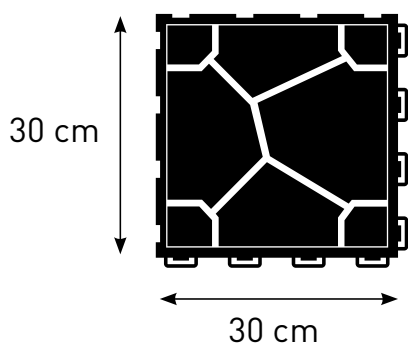

**9x = 0.81 m<sup>2</sup> = 2835 g**

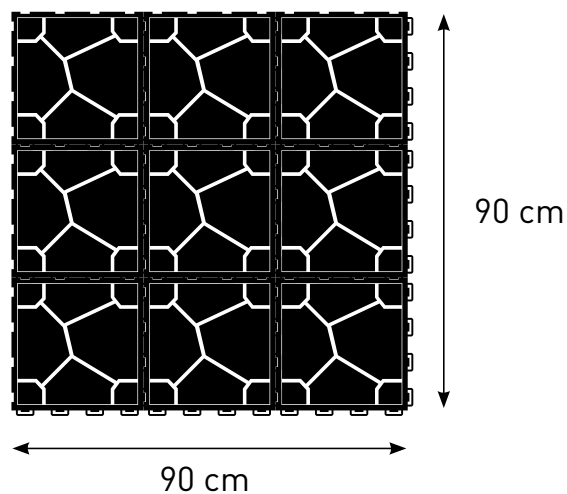

**Fatra, a. s.**  
třída Tomáše Bati 1541  
763 61 Napajedla  
Czech Republic

1st edition 1/2026



[www.fatra-injectionmoulding.com](http://www.fatra-injectionmoulding.com)  
[zuzana.gabrielova@fatra.cz](mailto:zuzana.gabrielova@fatra.cz)



+420 724 405 746